



GENERAL KNOWLEDGE

General Instruction for Air filter combination

For your own safty, please read the instruction below before you inquiring / using our products.

Safty precautions

- Products on the catalog because its variety, should let the the designer of the system or the person who decides the specifications to confirm the parts are suitable for the system or not.
- Incorrect operation compressed fluid will cause danger, please leave it to the the person who well-experienced if needs to install / maintenance the pneumatic machine and its spare parts.
- DO NOT operate / disassemble the machine before confirm safty, please make sure the anti-drop devices or anti-runaway devices is ready for the operation or not.

Design precautions

- Air filter, regulator, and the oil feeder material is Polycarbonate. DO NOT use in the environment with organic solvents, cutting oil, synthetic oil, alkali, or thread-locking fluid.
- Please avoid to the air filter, regulator, and the lubricator pressure filling or releasing frequently. It may cause outer casing damaged.
- Must install safty devices or exceed the set value of flow-control valve may cause secondary measurement device or machine itself damaged.

Installment

- Please confirm the air flow direction than proceed connecting installment. Reverse connection will cause operation error.
- Please avoid to the air filter, regulator, and the lubricator pressure filling or releasing frequently. It may cause outer casing damaged.
- Make sure have enough space for operate or maintenance. Regard to the space dimensions, please follow the sizes of various products
- Please fix pipes with the bracket, besides of steel, copper pipes.

Piping

- Please wash the pipeline before piping. Make sure no wastes, impurities, or foreign material.
- DO NOT act on the valve parts with any force like stretch, compress, or bend while piping.
- The product needs to be installed according to the direction of the fluid on the valve body.
- There might be mutual vibration occurs oscillation and abnormal sound if the regulator directly connect with solenoid valve.
- Tightening torque suggestion

Caliber	Tightening torque suggest
Rc 1/8	18~20 N•m
Rc 1/4	23~25 N•m
Rc 3/8	31~33 N•m
Rc 1/2	41~43 N•m
Rc 3/4	62~65 N•m
Rc 1	83~86 N•m

Spare Part number

Product Name	A Series				O Series		
	2000	3000	4000	5000	MINI	MIDI	MAXI
Filter 5 μ	XA-20	XA-30	XA-40 XA-40S	XA-50	XO-N5	XO-D5	XO-X5
Fliter cup (Manual)	CA-20	CA-30	CA-40	CA-50	CO-N <small>with cover</small>	CO-D <small>with cover</small>	CO-X <small>with cover</small>
Fliter cup (Auto)	CA-20D	CA-30D	CA-40D	CA-50D	CO-ND <small>with cover</small>	CO-DD <small>with cover</small>	CO-XD <small>with cover</small>
Pointer pressure gauge	PA40	PA40	PA50	PA50	PO40	PO50	PO50
Pressure gauge bracket	TA-20	TA-30	TA-40	TA-50			
Filter body bracket		LA-30	LA-40	LA-50	LO-M	LO-D	LO-X
L-type connector	Y-20L	Y-30L	Y-40L	Y-50L			
T-type connector	Y-20T	Y-30T	Y-40T	Y-50T			



GENERAL KNOWLEDGE

Maintenance

- Please release the rest of the pressure before maintenance or disassemble the machine. And follow the various note provisions
- Check the air filter, regulator, and the lubricator regularly, If any deterioration is found, please replace it in time.
- Check the air filter, regulator, and the lubricator regularly, If any dirty is found, please use neutral cleaner to clean, it may cause damaged if use other kinds of cleaner or washing fluids.
- Please install dryer or water remover front of the pipeline if the filter drains too much.

Filter

- Please check the filter regularly, If any dirty, waste, block is found, please replace it in time.
- To avoid the malfunction, please change the filter when pressure difference over 1 kgf/cm².
- Please check the water storage cup's water level regularly to avoid the storage exceed the limit.

Regulator

- Please unlock the knob to operate the pressure control, and lock the knob after finish adjust pressure.
- Check the pressure gauge on the primary and the secondary before adjustment. It will damage the parts if adjust too much.
- Please operate the knob manually, DO NOT use any tools.

Lubricator

- Please avoid protruding and bifurcated on the secondary piping, because it may cause oil feeder bad performance.
- Please select ISO VG32 lubricating oil.
- Please check the oil drop level regularly to avoid the malfunction from the machine needs to lubricate.

Main parts & Material

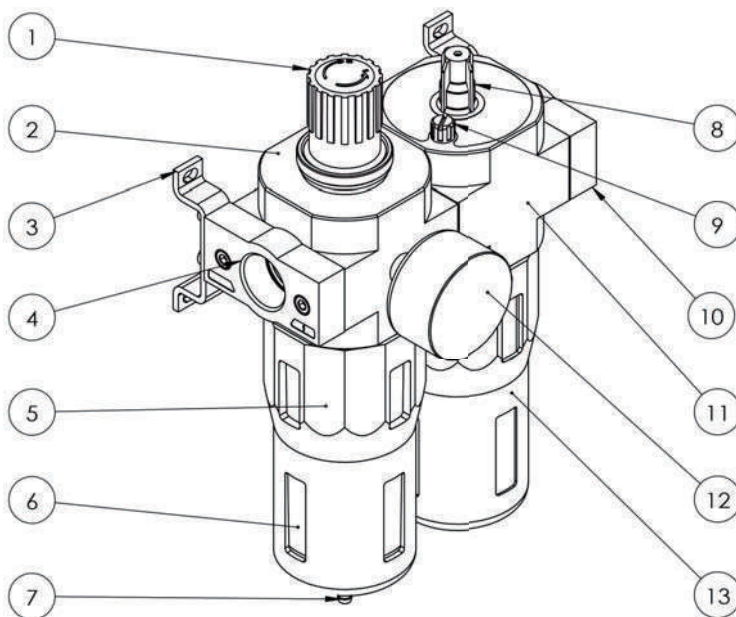

No.	Part name	Material
1	Knob	PP
2	Valve body	Die-cast al alloy + Paint
3	Bracket	SS41
4	Entry screw fixing block	Die-cast al alloy + Paint
5	Fliter body	Aluminum alloy + PVC
6	Auto drainage float	PP
7	Drain	PP
8	Oil level sight glass	PVC
9	Fliter body	NYLON
10	Exit screw fixing block	Die-cast al alloy + Paint
11	Oil feeder body	Die-cast al alloy + Paint
12	Pointer pressure gauge	Iron + Paint
13	Oil feeder cup	Aluminum alloy + PVC



PRODUCT/ Air Filter Combination

OR Series Regulator

Specifications Characteristics

JIS Symbol



Model	OR Series
Structure	Air pressure adjustment
Fluid	Compressed air
Temperature	-5°C - 60°C (Non frozen)
Environment	Temp. -10 - 55°C ; Humidity. 10 - 90% RH
Caliber	Thread 1/8" - 1" G (Standard)
Withstand Pressure	2.0 Mpa
Pressure range	0.1 - 1.6 Mpa
Adjustment range	0.1 - 1.2 Mpa
Accessories	Standard bracket ; Pointer pressure gauge 0 - 1.6Mpa
Installment	According to the fluid flow direction.

How to select model

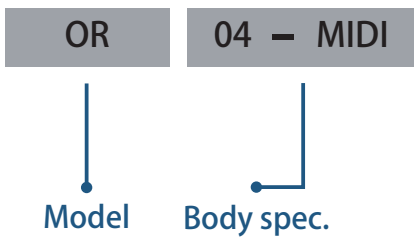

Diameter		Code
Small	1/8"	01-MINI
	1/4"	02-MINI
	3/8"	03-MINI
Midium	3/8"	03-MIDI
	1/2"	04-MIDI
	3/4"	06-MIDI
Large	3/4"	06-MAXI
	1"	10-MAXI





PRODUCT/ Air Filter Combination

Specifications list

Model	Adjustment Range	Diameter	Rated Flow (L/min ANR)	Gauge Aperture	Body Mat.
OR-MINI	0.1~1.2Mpa	1/8	800	1/8"	Aluminium alloy
		1/4	1500		
		3/8	1700		
OR-MIDI		3/8	3200	1/4"	
		1/2	3500		
		3/4	3500		
OR-MAXI	3/4	11000	1/4"		
	1	11500			

Flow characteristics

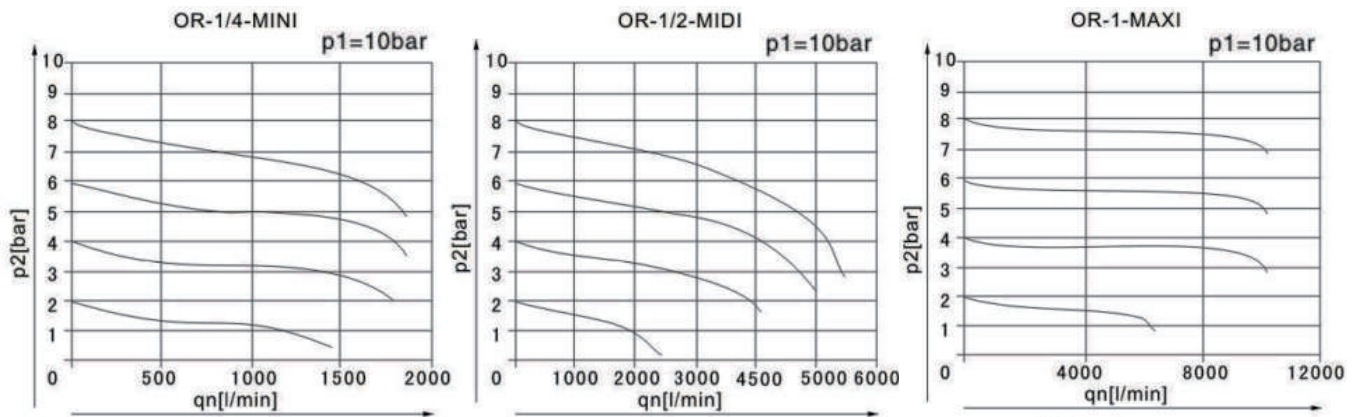

Dimensions (mm)

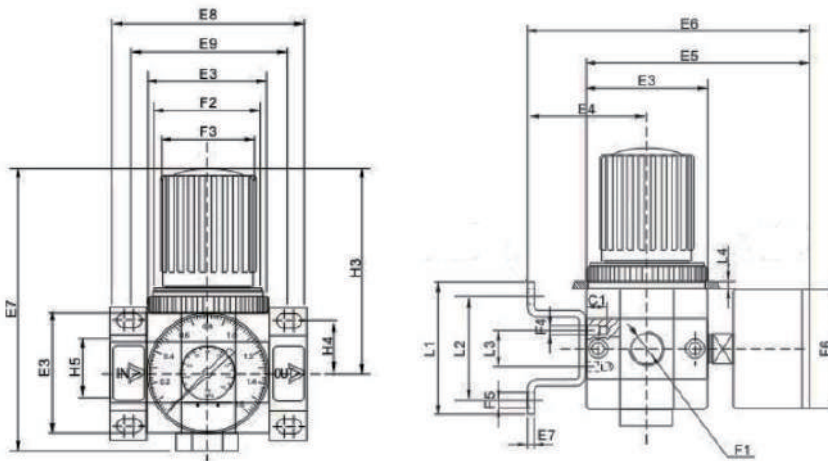

Model	E3	E4	E5	E6	E7	E8	E9	F1	F2	F3	F4	F5	F6	L1	L2	L3	H3	H4
MINI	40	39	76	95	96	64	52	1/8, 1/4, 3/8	M36*1.5	31	M4	4.5	40	44	35	11	69	17.5
MIDI	55	47	93	112	133	85	70	3/8, 1/2, 3/4	M52*1.5	50	M5	5.5	52	71	60	22	98	24.5
MAXI	66	53	104	124	146	116	91	3/4, 1	M52*1.5	50	M5	5.5	52	71	60	22	103	24.5