



GENERAL KNOWLEDGE

General Instruction for Solenoid

For your own safety, please read the instruction below before you inquiring / using our products.

Application

- Fluid in the pipeline MUST BE same as instruction shows on a solenoid.
- The fluid's temperature needs to be lower than valve's standard temperature.
- Our products normally allowed fluid's viscosity under 20 CST.
- If the highest working pressure difference lower than 0.05 MPa, please select Direct-Acting type. If the difference higher than 0.05 Mpa, please select Pilot-Operated type (Diaphragm type).
- Originally our products are working ONE DIRECTION, please install by fluid flow direction to avoid the reverse pressure. Could install stop-check valve if the counter current shows.
- Please install filter before installing Solenoid valve if the fluid isn't clean, to reduce any wastes and impurities from the pipeline.
- Please check your available flow aperture and nozzle diameter.
- Normally our products only have ON / OFF two switches, if its available, please install side-manual switch for your maintenance convenience.
- When there's water hammer phenomenon, please aware of valve switching time adjustment and choose the suitable product.
- Be aware of the effect caused by environmental temperature.

- Power voltage can allowed about $\pm 10\%$ fluctuation, volt-ampere is higher while using AC starts.
- The solenoid valve can be divided into two types. N.C. (Normal Closed) and N.O. (Normal Open), please select your suitable type.

Security

- Solenoids are not suitable for power on for a long time because of its design principles. If it powered on too long, metal coil will overheat cause shortened life and malfunction.
- Regular-type solenoid is not waterproof, please select waterproof type if the environment not allowed.
- Solenoid's highest standard pressure must exceed the highest pressure in the pipeline or it will cause shortened life and other malfunction.
- Please select full-stainless steel type if its corrosive fluid. High acid and alkaline fluids are suitable for PTFE valve body style.
- Dangerous environment that may cause explosion needs to select corresponding explosion-proof products.

Install Caution

- Clean the pipeline with fluids, make sure it already removed any dusts, impurities, rust and stop tapes.
- Please keep 1.5~2 turns screw thread while wrapping stop tapes.
- Sealant might be easily flow into the product, and may cause malfunction if using too much sealant while installing.

- It's better install with horizontal direction and coil face up.
- Make sure you have enough space for maintenance.
- Do not press coil parts while installing.
- Check the pipeline direction, leak or not, wire connection after the installment.

(Aluminum alloy)

Caliber	Tightening torque suggest
Rc 1/8	7~9 N•m
Rc 1/4	12~14 N•m
Rc 3/8	22~24 N•m
Rc 1/2	28~30 N•m
Rc 3/4	31~33 N•m
Rc 1	36~38 N•m
Rc 1-1/4	40~42 N•m
Rc 1-1/2	48~50 N•m
Rc 2	57~56 N•m

(Brass, Stainless steel)

Caliber	Tightening torque suggest
Rc 1/8	18~20 N•m
Rc 1/4	23~25 N•m
Rc 3/8	31~33 N•m
Rc 1/2	41~43 N•m
Rc 3/4	62~65 N•m
Rc 1	83~86 N•m
Rc 1-1/4	97~100 N•m
Rc 1-1/2	104~108 N•m
Rc 2	132~136 N•m



GENERAL KNOWLEDGE

Precautions in maintenance

- Solenoid coil and its drive element will heat after power on, please DO NOT touch or it will cause scald.
- If you need to decompose our product to inspect, please remove the power, and release the rest of the pressure in the pipeline. Make sure you are safe then continue the progress.
- To avoid rubber parts in the valve expansion or deformation, Please use neutral cleaner when you are cleaning the parts of valve.
- If you are not going to use our product of a long time after you used, please completely remove the rest of the fluid in the valve. If there's any fluid residue, it will get rusty in the next time you use and cause poor product performance.
- To keep its best situation, please arrange regular inspect and change parts by its usage frequency.

Exploded view

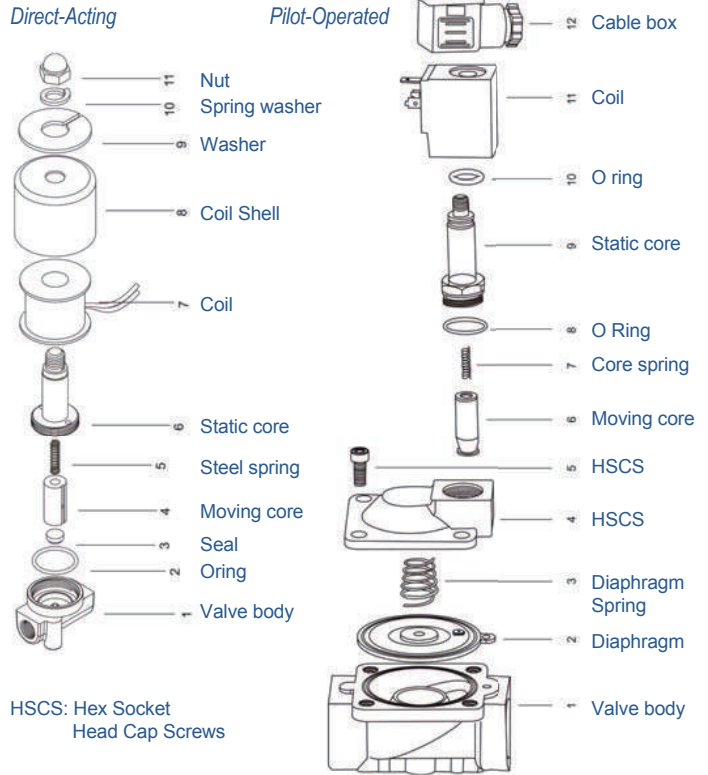

Cable box connection

DIN Cable box (Pg9)

1. Please use insulated wire, Outer diameter $\varnothing 6 \sim \varnothing 10$ mm, section area $0.5 \sim 1.5 \text{ mm}^2$.
2. Tightening torque suggest $0.5 \text{ N} \cdot \text{m}$
3. If you need to change wire direction, take out cable box from shell, rotate 180 degrees then press into shell again.
4. Follow instruction from step 1 to step 7.

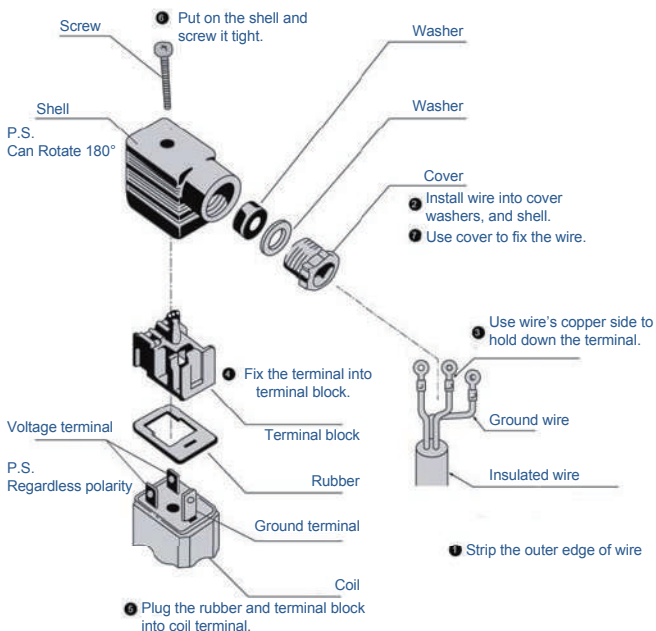

DIN Cable box (Pg11)

1. Please use insulated wire, Outer diameter $\varnothing 6 \sim \varnothing 10$ mm, section area $0.5 \sim 1.5 \text{ mm}^2$.
2. Tightening torque suggest $0.5 \text{ N} \cdot \text{m}$
3. If you need to change wire direction, take out cable box from shell, rotate 90 degrees then press into shell again.
4. Follow instruction from step 1 to step 7.

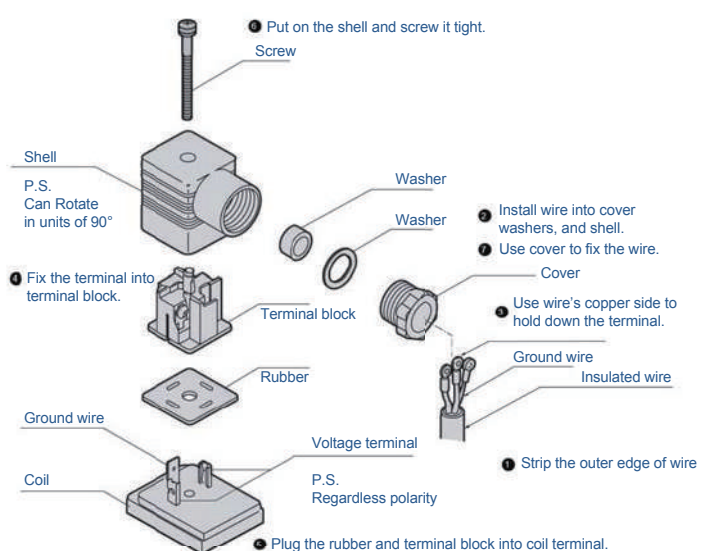



PRODUCT/ SOLENOID VALVE

3V1 Series 3 Port Solenoid Valve

JIS Symbol

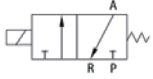

Specifications Characteristics

Model	3V1 Series
Structure	Direct-Acting, 3/2 way N. C. (Normal Close)
Fluid	Air, Inert gas
Temperature	-5°C - 70°C
Environment	Temp. -10 - 55°C ; Humidity. 10 - 90% RH
Caliber	Thread M5 - 1/8" G (Standard)
Aperture	1.2mm
Pressure	0 - 8 kgf/cm ²
Withstand pressure	15 kgf/cm ²
Material	Aluminum alloy
Diaphragm	NBR
Voltage	Reference below, Allowed voltage flow range ± 10%
Consumption	AC220V 5.5VA ; DC24V 4.8W
Protect Level	IP65
Install	According to the fluid flow direction.

How to select model

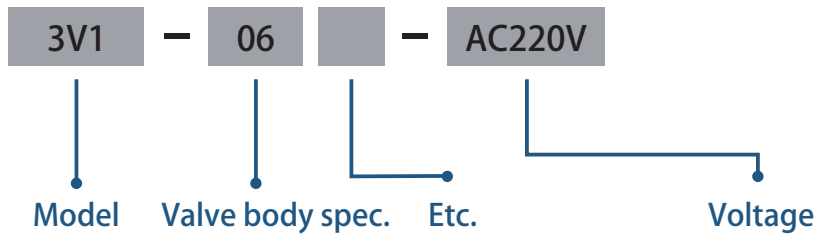

Diameter	Code
M5	M5
1/4"	08

Spec.	Code
DIN Standard Coil	
Cable Coil	F

Voltage
AC110V
AC220V
AC380V
AC24V
DC24V
DC12V





PRODUCT/ SOLENOID VALVE

Internal structure

No	Designation
1	Connector
2	Connector washer
3	Nut
4	Coil
5	Pilot units
6	O-ring
7	Spring
8	Valve body

Main Parts Material

Part name	Material
Valve body	Aluminum Alloy
Connector	Engineering Plastic
Connector washer	NBR
Pilot units	Pure steel+Cu+Stainless steel
Diaphragm	NBR
Nut	POM+Carbon steel
Coil	Brass wire + Heat resistance colophony

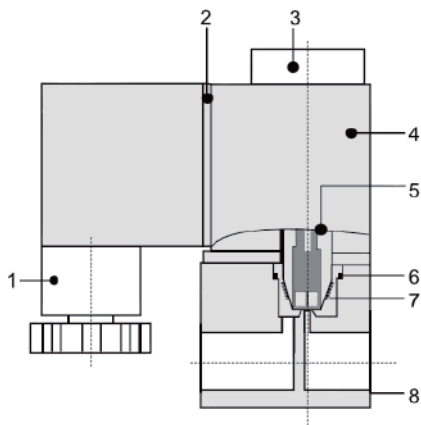

Flow Chart

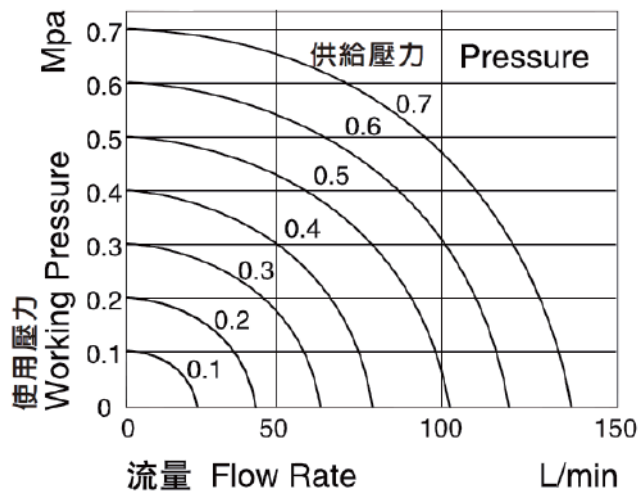

Dimension (mm)

